

SANYO

VCC-WB2000

INSTRUCTION MANUAL

Network Camera

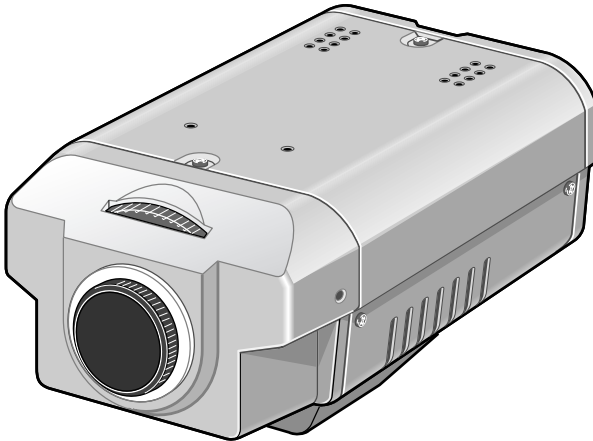

About this manual

Before installing and using this unit, please read this manual carefully. Be sure to keep it handy for later reference.

Contents

Information to user.....	2	Alarm Setting.....	35
Precautions.....	3	■ External Alarm Sensor Settings.....	35
Features.....	4	■ MOTION DETECTOR SET Settings.....	37
Accessories.....	4	■ Alarm Data Recording Capacity.....	38
Operating environment.....	4	■ Expansion memory cards.....	38
Name and Function of Each Part.....	5	■ Recording Alarm Data.....	39
Attaching the Lens.....	7	■ Playing Back Alarm Data.....	39
Flange Back Adjustment.....	8	■ BUFFER DATA VIEW screen.....	40
Connections.....	9	■ Playing Back Expansion Memory Card Images.....	41
■ Basic Connections.....	9	■ Deleting Alarm Images.....	41
■ Connecting to a LAN.....	10	■ Pre-alarm and Post-alarm Recording...2	42
■ Connecting to the Internet.....	10	CLOCK SET Settings.....	43
■ PPP (Dial-up) Connections.....	11	RS-232C Settings (RS-232C SET).....	44
Network Camera Settings.....	12	STATUS Checking.....	44
1 Installation of Plug-in Software.....	13	Troubleshooting.....	45
■ Browser Settings.....	15	■ If the camera cannot be connected.....	45
■ Cookie Settings.....	15	■ If you forget the IP Address.....	45
2 Computer and Camera Settings.....	16	Specifications.....	46
3 Network Connection Settings.....	17		
A NETWORK SET Settings.....	18		
B WIRELESS LAN SET Settings.....	20		
C PPP SET Settings.....	22		
Menu Screen and Main Menu.....	24		
■ Main menu.....	24		
■ Menu screen.....	25		
Viewing Camera Images.....	26		
LIVE VIEW Settings.....	28		
■ Saving Images into a Computer.....	30		
VIEW FRAME Operations.....	31		
CAMERA Settings.....	32		
■ Setting the camera title.....	34		

Information to user

Safety Guard

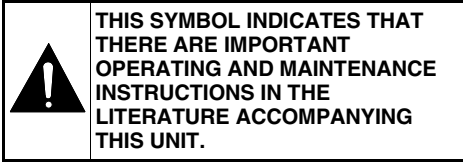

WARNING:
TO PREVENT THE RISK OF FIRE OR ELECTRIC SHOCK , DO NOT EXPOSE THIS APPLIANCE TO RAIN OR MOISTURE.

For the customers in Canada
This Class B digital apparatus complies with Canadian ICES-003.

Pour la clientèle canadienne
Cet appareil numérique de la Classe B est conforme à la norme NMB-003 du Canada.

This installation should be made by a qualified service person and should conform to all local codes.

This equipment has been tested and found to comply with the limits for a Class B digital device, pursuant to Part 15 of the FCC Rules.

These limits are designed to provide reasonable protection against harmful interference in a residential installation. This equipment generates, uses, and can radiate radio frequency energy and, if not installed and used in accordance with the instructions, may cause harmful interference to radio communications.

However, there is no guarantee that interference will not occur in a particular installation. If this equipment does cause harmful interference to radio or television reception, which can be determined by turning the equipment off and on, the user is encouraged to try to correct the interference by one or more of the following measures:

- Reorient or relocate the receiving antenna.
- Increase the separation between the equipment and receiver.
- Connect the equipment into an outlet on a circuit different from that to which the receiver is connected.
- Consult the dealer or an experienced radio/TV technician for help.

This device complies with Part 15 of the FCC Rules. Operation is subject to the following two conditions: (1) This device may not cause harmful interference, and (2) this device must accept any interference received, including interference that may cause undesired operation.

Changes or modifications not expressly approved by **Sanyo** may void the user's authority to operate this camera.

Precautions

■ In case of problem

Do not use the camera if smoke or a strange odour comes from the unit, or if it seems not to function correctly. Disconnect the power cord immediately, and consult your dealer (or a Sanyo Authorized Service Centre).

■ Do not open or modify

Do not open the cabinet, as it may be dangerous and cause damage to the unit. For internal settings and repairs, consult your dealer (or a Sanyo Authorized Service Centre).

■ Do not put objects inside the unit

Make sure that no metal objects or flammable substance get inside the camera. If used with a foreign object inside, it could cause a fire, short-circuits or damages.

If water or a liquid gets inside the camera, disconnect the power cord immediately, and consult your dealer (or a Sanyo Authorized Service Centre). Be careful to protect the camera from rain, sea water, etc.

■ Be careful when handling the unit

To prevent damages, do not drop the camera or subject it to strong shock or vibration.

■ Install away from electric or magnetic fields

If installed close to a TV, radio transmitter, magnet, electric motor, transformer, audio speakers the magnetic field they generate will distort the image.

■ Protect from humidity and dust

To prevent damages to the camera, do not install it where there is greasy smoke or steam, where the dampness may get too high, or where there is a lot of dust.

■ Protect from high temperatures

Do not install close to stoves, or other heat generating devices, such as spotlights, etc., or where it could be subject to direct sunlight, as that could cause deformation, discoloration or other damages.

Be careful when installing close to the ceiling, in a kitchen or boiler room, as the temperature may raise to high levels.

Install where the temperature range will stay between -10°C and 50°C . (no condensation)

■ Cleaning

- Dirt can be removed from the cabinet by wiping it with a soft cloth. To remove stains, wipe with a soft cloth moistened with a soft detergent solution and wrung dry, then wipe dry with dry soft cloth.
- Do not use benzene, thinner or other chemical product on the cabinet, as that may cause deformation and paint peeling. Before using a chemical cloth, make sure to read all accompanying instructions. Make sure that no plastic or rubber material comes in contact with the cabinet for a long period of time, as that may cause damage or paint peeling.

Features

■ Web Server Function

This camera is equipped with a web server function. The camera can be accessed using a computer's web browser in order to view the camera images. In addition, up to a maximum of 16 users can simultaneously access a single camera on the network.

■ Network Connections

This camera is equipped with both an Ethernet connector and an RS-232C connector, allowing it to be connected to a variety of different network environments, such as LANs and the Internet.

■ Wireless LAN Compatibility

The camera can also be used in a wireless LAN environment by installing the specified wireless LAN card.

■ Adoption of JPEG2000

The images captured by the camera are compressed using the JPEG2000 format before transmission. In comparison to conventional JPEG formats, this format produces very little image deterioration and allows large volumes of data to be transmitted quickly (maximum 30 fps).

Note: The transmission rate will vary depending on individual network conditions.

A network environment that can transmit data at high speeds is required in order to transmit data at 30 fps.

■ Alarm Recording and Playback Functions

The built-in motion sensor detects movement, and the camera can also be connected to an external alarm sensor that is set to detect abnormalities, so that images can be recorded and played back when an alarm occurs.

Accessories

- ① Setup CD-ROM 1 pc.
- ② Lens iris plug (4-pin). 1 pc.
- ③ Clamping core 2 pc.

Operating environment

The camera requires the following conditions to operate.

- **OS:** In this manual, the English versions of the Microsoft® Windows® 98 operating system, the Microsoft® Windows® Millennium Edition operating system, the Microsoft® Windows® 2000 operating system and the Microsoft® Windows® XP operating system are all referred to as Windows.
Intel and Pentium are trademarks or registered trademarks of Intel Corporation or its subsidiaries in the United States and other countries.
- **CPU:** Intel® Pentium® III 750 Mhz or higher or similar with equivalent speed capacity (2 GHz Pentium® IV recommended)
Microsoft and Windows are trademarks, or registered trademarks of Microsoft Corporation in the United States and/or other countries.
- **Memory:** 128 MB or more (256 MB or more recommended)
- **Drive:** CD-ROM drive
- **Network card:** 10Base-T / 100Base-TX
- **Protocols:** TCP/IP, PPP, FTP, HTTP
- **Browser:** Microsoft Internet Explorer 5.5 SP2 or later
- **Computer monitor display size of 1024 x 768 pixels or greater**

Session disconnect time (3 minutes)

If there is no activity (such as a screen refresh) for three minutes when a setting screen or other screen is displayed, the current session is disconnected and screen operations will not be possible. In such cases, the language selection screen will be displayed when mouse or other operations are attempted.

Name and Function of Each Part

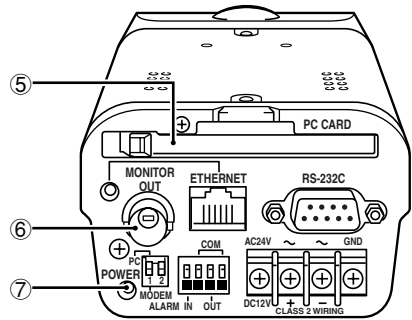
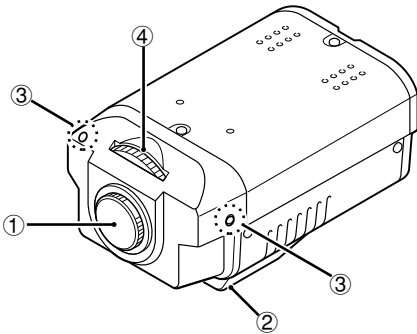

① Lens mount cap

Attach this cap to protect the lens mounting section. When using the camera, remove the cap and attach the automatic iris-type lens (sold separately).

② Camera mounting bracket

This bracket can be installed to either the top or bottom of the camera as desired. When changing the position of the camera mounting bracket, you should always reuse the screws that have been removed.

Note: If using a camera mounting bracket (sold separately), select a location that is strong enough to bear the full weight of the camera and the mounting bracket for long periods, and install the camera and mounting bracket securely.

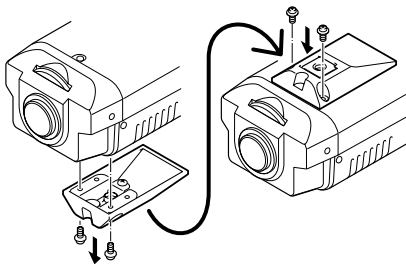

③ Flange back locking screws (p. 8)

④ Flange back adjustment dial (p. 8)

⑤ PC CARD slot

Use this slot to insert a memory card or wireless LAN card.

Note: Make sure that the camera's power is turned off before inserting the card.

⑥ MONITOR OUT connector

When setting up the camera, use this connector to connect the camera to the VIDEO IN connector of a monitor for adjusting the angle of view and focus.

⑦ POWER indicator

This indicator illuminates when 24 V AC or 12 V DC is being supplied to the power input terminals of the camera.

Name and Function of Each Part

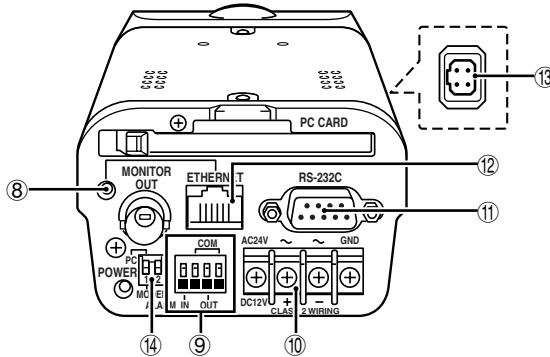

⑧ Link indicator

This indicator illuminates when the camera is connected to a network. It flashes while data transmission is in progress.

⑨ ALARM terminals

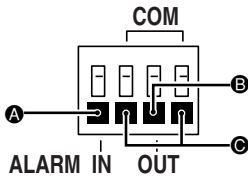

Ⓐ ALARM IN terminal

Connect this terminal to an infrared sensor or similar use in external detection of intruders.

Ⓑ ALARM OUT terminal

Connect this terminal to a buzzer or lamp that is used to warn when the motion sensor detects an alarm.

Ⓒ Ground terminal (COM)

⑩ 24 V AC/12 V DC input terminals (AC24V, DC12V, GND)

⑪ RS-232C connector

Use this connector to connect the camera to a modem for transmission of data along telephone lines, or for connecting the camera to a computer.

Use the **PC/MODEM** select switch to change the camera operation between modem and computer operation.

⑫ ETHERNET connector

Use this connector to connect the camera directly to a computer or to a network. Use a 10Base-T or 100Base-TX (Category 5, UTP) cable to make the connection.

⑬ Lens iris output connector

Connect this connector (4-pin socket) to the lens iris plug of the automatic iris-type lens (sold separately).

⑭ PC/MODEM select switch

Use this switch to set the function of the RS-232C connector when connecting the camera directly to either a modem or computer.

Note:

- Make sure that the camera's power is turned off before setting the function of the RS-232C connector.
- Using the RS-232C connector to connect the camera to a computer is only done for service purposes. You should not use this switch yourself.

Attaching the Lens

Use a DC-type automatic iris-type lens (sold separately).

1 Remove the lens mount cap.

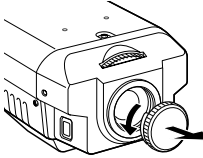

2 Attach the CS mount-type lens.

Note:

The "L" part of the lens should be 5 mm or less in length. If a lens that does not conform to this standard is used, it will not be possible to attach the lens correctly.

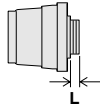

Gently screw the lens into the camera.

The following automatic iris-type lenses can be used.

- VCL-CS8LY (standard, $f = 8$ mm)
- VCL-CS4LY (wide angle, $f = 4$ mm)
- VCL-CS2LY (extra wide angle, $f = 2.8$ mm)

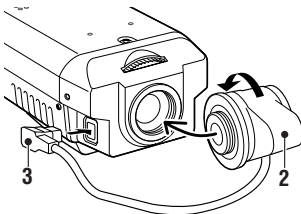

■ For C mount type

In order to allow correct adjustment of the flange back, attach the C mount adapter ring (option) to the lens before attaching the lens to the camera.

3 Connect the lens iris plug to the lens iris output connector of the camera.

Lenses from other manufacturers may have different plug shapes and specifications. In such cases, you may need to rewire the lens iris plug.

- | | |
|--------------------|------------------|
| ① (-) control coil | ③ (+) drive coil |
| ② (+) control coil | ④ (-) drive coil |

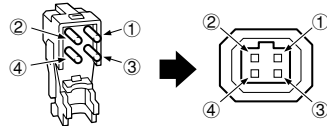

(Connecting to the lens iris plug)

- ① Cut off the plug of the lens cable, cut off approximately 8 mm of the insulation, and then strip the ends of the cable sheaths leaving approximately 6 mm of sheath intact.

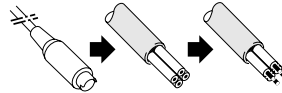

- ② Solder the ends of the cable wires to the ends of the pins, and then attach the cover of the lens iris plug.

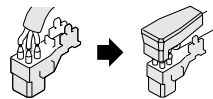

Flange Back Adjustment

The flange back is the distance between the lens (sold separately) and the image capturing surface of the camera. It is adjusted at the time of shipment from the factory to accommodate the types of lenses that are generally assumed to be in use.

Accordingly, the flange back does not normally need to be adjusted. However, if attaching a zoom lens and changing from wide angle to telephoto, the images may not be captured in proper focus, and so in such cases the flange back should always be adjusted by following the procedure given below.

1 Connect a cable between the **MONITOR OUT** connector of the camera and the **VIDEO IN** connector of a monitor.

2 Turn on the camera's power.

Adjust the flange back while viewing the camera images on the monitor.

3 Use a Phillips screwdriver to loosen the two flange back locking screws.

4 Move the zoom lens to the telephoto setting, and then use the lens focus ring to adjust the focus.

5 Move the zoom lens to the wide angle setting, and then use the flange back adjustment dial to adjust the focus.

6 Move the zoom lens from wide angle to telephoto (repeating steps 4 and 5) and check that the images are properly focused. Then tighten the flange back locking screws.

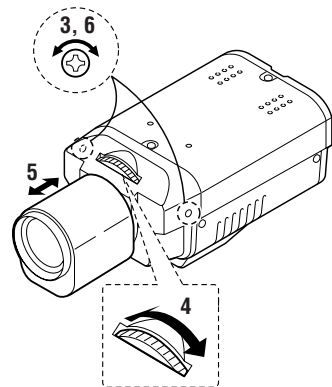
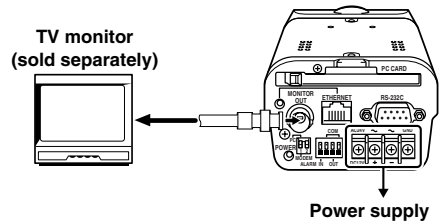

Connections

Turn off the power for all equipment before making any connections.

Basic Connections

1 Connect the camera to a computer.

Connect a cable between the ETHERNET connectors of the camera and the computer.
Use a crossed wire-type Ethernet cable.

2 Connect the power supply.

When using this unit, the supplied clamping core **A** must be installed on the power cord, in order to prevent electromagnetic interference to the other devices connected.

- If using a commercially-available 24 V AC adapter, always be sure to connect the ground wire (18AWG or higher) to the ground terminal. (**Figure 1**)
- If using a 12 V DC power supply, make the connections as shown in **Figure 2**.

Note:

- In order to avoid any problems with the camera and the power supply, take sufficient care to ensure that the polarities are correct when connecting the power supply.
- When the accessory ferrite cores are attached, they will increase the load on the cable, so after doing the installation, adjust the cable accordingly.

3 Insert the power cord plug into a wall outlet.

The POWER indicator (A) will illuminate.

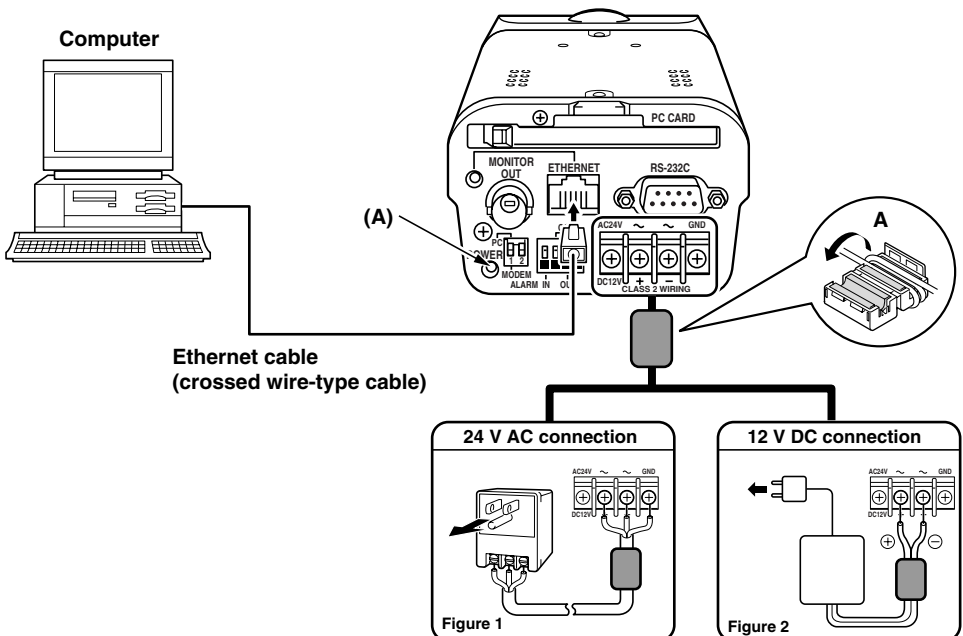

Connections

■ PPP (Dial-up) Connections

If connecting the camera using PPP, you will need to install the Network Archiving software (sold separately). In addition, the data that is transmitted via PPP connections consists of alarm images and alarm information. In addition to the connection method shown below, you can also connect the camera to an ISDN terminal adapter and use the Network Archiving software. Refer to the documentation provided with the Network Archiving software for further details.

Use a serial cable to connect the RS-232C connector of the camera to a modem. Set pin 1 of the PC/MODEM select switch to the **“MODEM”** setting. You do not need to change the setting for pin 2.

Note: When using modem connections, you cannot access the camera using a computer's web browser. You should normally connect the camera to a wired LAN or wireless LAN.

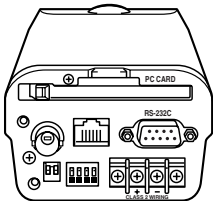

Network Camera Settings

In order to use the camera as a network camera, you must make the following settings in the order given.

When making network connection settings, the network settings must always be made first.

1 Installation of Plug-in Software (p. 13)

Use the accessory setup CD-ROM to set u the computer.

2 Computer and Camera Settings (p. 16)

Connect the computer and the camera directly, and access the camera using the computer's web browser.

3 Network Connection Settings (p. 17)

More than one camera can be connected to the same network, but before the cameras can be connected, you need to make various settings for each camera such as assigning IP addresses. The following three types of network connections can be made. Set the cameras in accordance with the purpose of use.

A NETWORK settings (p. 18)

These settings are for when the camera is being connected to a LAN. This is the normal type of connection to use for this camera.

B WIRELESS LAN settings (p. 20)

These settings are used when connecting the camera to an access point for a wireless LAN.

C PPP (dial-up) SET settings (p. 22)

These settings are used when using a modem to connect the camera to the Internet.

Note: If using a modem to make a dial-up connection, you will need to use the Network Archiving software that is sold separately.

Network Camera Settings

1 Installation of Plug-in Software

Install the plug-in software (on the setup CD-ROM) onto the computer that is to be used. Installing the plug-in software makes it possible to view live images from network cameras using the computer's web browser.

1 Turn on the power for the computer.

After Windows has loaded, continue to the next step.

2 Insert the setup CD-ROM into the CD-ROM drive of the computer.

3 Click Start and then click Run.

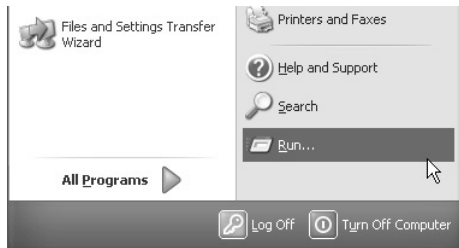

4 Type D:\Setup.exe.

Type the drive letter for the CD-ROM drive of the computer in place of "D".

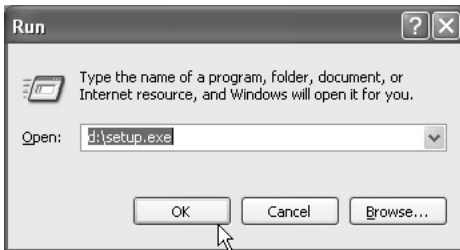

5 Click the [OK] button.

After a short wait, the installation window will appear.

Note: Simply answer the prompts that appear on the screen in order to continue installing the software. The installation program has been set up beforehand to install the software correctly.

6 Click the [Next] button.

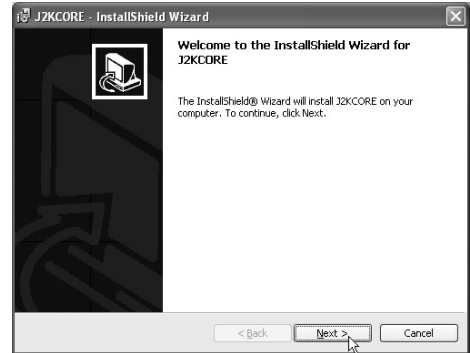

7 Read the license agreement, and select Agree if you agree to the terms of the license. Then click the [Next] button.

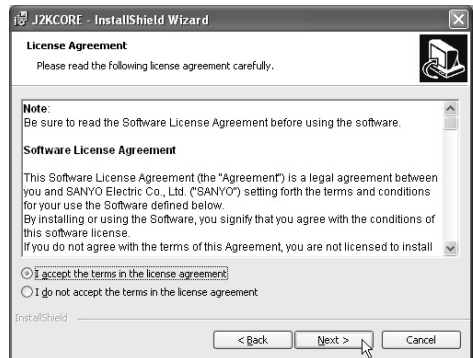

Network Camera Settings

8 Type in your username and organization name, and then click the [Next] button.

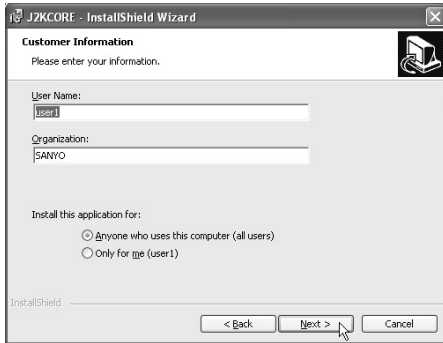

9 Click the [Install] button.

Installation of the software will start and the window display will change to show the installation progress.

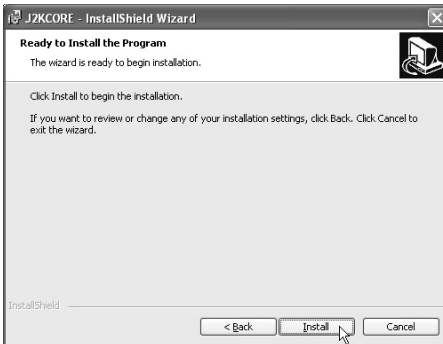

10 Click the [Finish] button.

This completes the installation of the plug-in software.



(Uninstalling the plug-in software)

To uninstall the plug-in software, select “Add/Remove Programs” from the Windows Control Panel, and delete “J2KCORE”.

Network Camera Settings

Browser Settings

Check that the Security settings for Microsoft Internet Explorer are set as described below. Select Internet Options from the Tools menu, click the Security tab and then click the Custom Level button to display the settings.

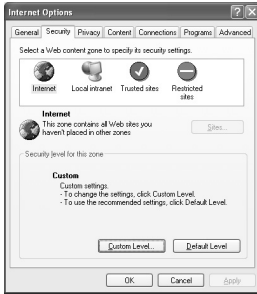

1 Set “Run ActiveX controls and plug-ins” to “Enable” in the “ActiveX controls and plug-ins” section.

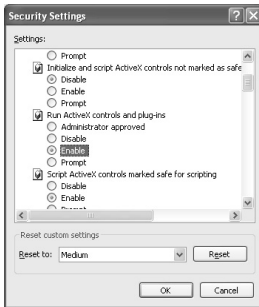

2 Set “Active scripting” to “Enable” in the “Scripting” section.

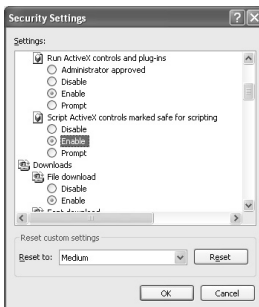

Cookie Settings

The camera uses cookies.

If using Internet Explorer Version 6.0 as the web browser, select Internet Options from the Tools menu, click the Privacy tab and then move the slide bar to the “Medium” position.

Note: If using Internet Explorer Version 5.5 SP2, click the Security tab.



Network Camera Settings

2 Computer and Camera Settings

Once the plug-in software has been installed, use the computer's web browser to access the camera.

Note: The network camera handles large volumes of image data that has been compressed into JPEG2000 format. In order to provide smooth access to the camera, you should close any other applications that you do not need to have open.

1 Click on the Network icon in the computer's Control panel, and then set the computer's IP address and subnet mask.

- **IP address:** Type in "192.168.0.*". The camera's IP address is set to "192.168.0.2", so set "*" to "3" or greater.
- **Subnet mask:** Type in "255.255.255.0".

2 Use an Ethernet cable to connect the ETHERNET connector of the camera to the computer.

To make an external connection between the camera and the computer, refer to "Basic connection" in the "Connections" section. (p. 9)

3 Turn on the power for the camera.

4 Start the web browser on the computer.

5 Type `http://192.168.0.2` into the location bar of the web browser, and then press the [Enter] key.

The password entry window will be displayed.

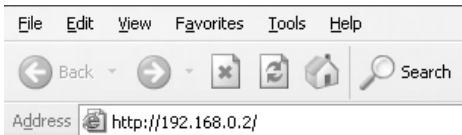

6 Type in "ID3" as the Username and "3333" as the password, and then click the [OK] button.

The language selection window will be displayed.

Note: In order to carry out the various settings listed here, you need to enter the password "3333" that has been set for administrator level access at the time of shipment from the factory. Different passwords can be set for up to three access levels. Refer to "Network Settings" for details on setting the passwords. (p. 18)



Language selection window

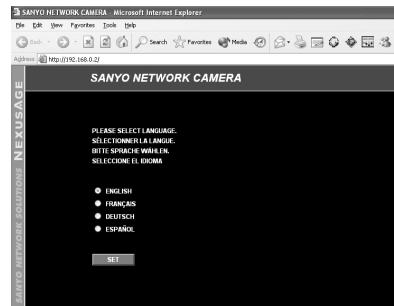

Network Camera Settings

3 Network Connection Settings

1 Select the desired language (e.g. English) in the language selection window, and then click the [SET] button.

The main menu window will be displayed.

Available languages: English, French, German, Spanish

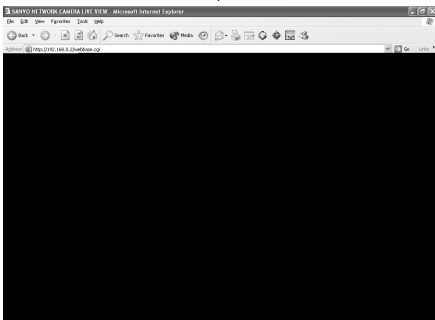
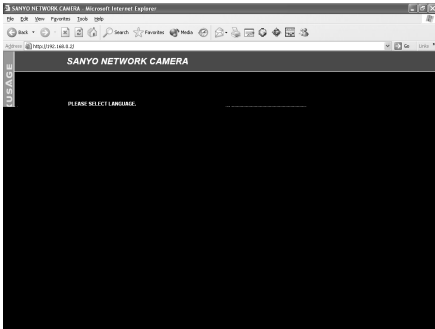

(Closing the initial window)

To change the language or stop tasks such as live image monitoring, click the network disconnect button.



“SANYO NETWORK CAMERA, THE UNIT IS DISCONNECTED” will be displayed, and the camera will be disconnected from the network. To reconnect the camera to the network, click the [Refresh] button in the title bar.

Note:

- If you close the web browser without clicking the network disconnect button, the message “THE UNIT IS BUSY!” may be displayed the next time you try to access the camera. Always be sure to use the network disconnect button to close communication with the camera.
- If a problem with the web browser occurs which causes the web browser to close abnormally without using the network disconnect button, wait three minutes or more, and then re-access the camera.

2 Click the [NETWORK] button in the main menu.

Note: When making the network connection settings, always make sure that you change the network settings first. After making these settings, you can then change the wireless LAN or PPP settings as required.

Network Camera Settings

A NETWORK SET Settings

These settings are used in order to connect the camera to the network.

Note: Check with the network system administrator for details on settings related to the network itself, such as IP address settings.

NETWORK SET	SET VALUE			
IP ADDRESS	192	168	0	2
SUBNET MASK	255	255	255	0
GATEWAY	192	168	0	1
PASSWORD (4-8)	ID1	1111		
	ID2	2222		
	ID3	3333		
NETWORK SPEED	NO LIMIT			
HTTP PORT NUMBER	80			
MAC ADDRESS	08 - 00 - 7B - 81 - 18 - 05			

Default settings displayed
Reset if necessary

1 NETWORK button
2 Password field
3 Network Speed dropdown
4 HTTP Port Number field

SET

1 Click the [NETWORK] button in the main menu.

NETWORK

The initial NETWORK SET window will be displayed. The default settings for each item will be displayed automatically. Check with the network system administrator or Internet Service Provider if you need to change any of the following settings.

- IP ADDRESS
- SUBNET MASK
- GATEWAY

2 Set the password.

There are three access levels available (User, Operator and Administrator) and separate passwords can be set for each level. The range of operations varies for each level as shown in the table below.

Username	ID1	ID2	ID3
Access level	User	Operator	Administrator
Password (default)	1111	2222	3333
Live image viewing	○	○	○
Menu settings	×	○	○
Main menu button operation	×	△	○

△: Camera settings only

Note: The passwords are set as shown in the table above at the time of shipment from the factory. However, it is recommended that you change them whenever possible for security purposes.

3 Once you have finished changing the settings, click the [SET] button.

Network Camera Settings

① Changing a password

Example: To change the password for the Administrator level (ID3) to “1234”

Passwords can consist of between 4 and 8 numerals.

- ☛ Type “1234” as the password in the password column for ID3, and then click the [SET] button.

A pop-up menu will be displayed. Click the [OK] button. The following screen will then be displayed. Check that the details are correct, and then close the window.

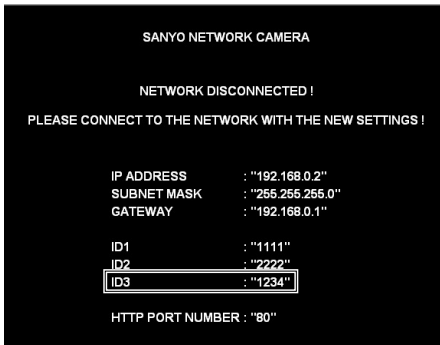

(When a password has been changed)

When the camera and the computer are connected once more, the network password entry window will be displayed, so check the username and type in the new password (“1234”) into the Password box.

② NETWORK SPEED

This sets the speed of data transmission by the camera.

Available settings:

NO LIMIT: No limit on data transmission speed
64, 128, 256, 512, 1024 (Kbps)

③ HTTP PORT NUMBER

When more than one camera is connected to a broadband router and a single IP address for that router is being used to make the images being monitored by the camera publicly available over the Internet, this setting is used to set the router’s port number to use. Refer to the documentation provided with the broadband router for further details.

Normally the HTTP PORT NUMBER setting should be left at the default value of “80” without being changed, even if more than one camera is connected to the network.

④ MAC ADDRESS display

This shows the Mac address for the camera.

Note:

- Up to a maximum of 16 individual users can access a single camera on the network at the same time. However, only one user out of this maximum of 16 users can be accessing at Operator or Administrator level at any one time.
- Depending on the network environment, it may not be possible for 16 users to be connected to a camera at the same time. Once a user has accessed a camera, the network may not allow further accesses, so if this happens, reduce the resolution or increase the compression ratio for the transferred data to reduce the volume of data being transferred.
- If a 17th user tries to access a camera, the message “**THE UNIT IS BUSY!**” will be displayed on their screen. Depending on the network environment, the message “**THE UNIT IS BUSY!**” may be displayed on a user’s computer screen even when less than 16 users are accessing a camera.
- If a user at Administrator level accesses a camera while a user at Operator level is accessing the camera, the Administrator level user will have priority. In such cases, the Operator level user will be disconnected and the message “**THE UNIT IS DISCONNECTED!**” will be displayed on their screen.
- Depending on the network environment, the speed of data transmission to users may drop if the number of users accessing the same camera increases, and operations such as refreshing of images may become delayed.

Network Camera Settings

B WIRELESS LAN SET Settings

These settings are used in order to connect the camera to an access point for a wireless LAN.

WIRELESS LAN SET	SET VALUE
WIRELESS LAN USE	USE
WIRELESS LAN ADAPTER	IEEE 802.11 Wireless LAN/PC Card
FIRMWARE VERSION	1.0
MAC ADDRESS	00:60:B3:71:46:AB
CURRENT TX.RATE	AUTO
CURRENT CHANNEL	1 [FCC]
ESS ID	WebCameraNet009
BSS ID	00:00:B3:16:A2:0D
WEP ENCIPHERMENT	DISAB_E
ENCRYPTION KEY	1: <input type="text"/> 2: <input type="text"/> 3: <input type="text"/> 4: <input type="text"/>
IP ADDRESS	132 . 168 . 1 . 2
SUBNET MASK	255 . 255 . 255 . 0
GATEWAY ADDRESS	132 . 168 . 1 . 254

SET

1 Insert a wireless LAN card (sold separately) into the PC CARD slot. (p. 10)

2 Click the [WIRELESS LAN] button in the main menu.

WIRELESS LAN

The initial WIRELESS LAN SET window will be displayed.

3 Select "USE" from the [WIRELESS LAN USE] drop-down list box.

* Items indicated by * will be displayed automatically when a wireless LAN card is inserted.

4 Change the following settings if required.

① CURRENT CHANNEL

This shows the frequency channel for the access point that is to be used to connect to.

② ESS ID (Extended Service Set)

Set the verification code to be used in order to connect the camera to the access point of the wireless LAN. The verification code can be up to a maximum of 32 characters, and can include alphanumeric characters only. Type in the same ESS ID for the access point being connected to.

Network Camera Settings

③ WEP ENCIPHERMENT

This is a security function that encrypts the data being transmitted so that it cannot be intercepted by an unauthorized third party. The default setting is “**DISABLE**”. To enable encryption, select the number of bits for the encryption key to use from the drop-down list box.

Available settings:

- **WEP40**: The encryption key can consist of up to 5 alphanumeric characters.
- **WEP128**: The encryption key can consist of up to 13 alphanumeric characters.

④ ENCRYPTION KEY

Up to four types of encryption key can be set. The encryption settings are as follows. For example, if “**WEP40**” is selected from the [WEP ENCIPHERMENT drop-down list box, select an encryption key of 5 characters from the [ENCRYPTION KEY] boxes.

If “**WEP128**” is selected, select an encryption key of 13 characters.

- **WEP40**: The encryption key can consist of up to 5 alphanumeric characters.
- **WEP128**: The encryption key can consist of up to 13 alphanumeric characters.

The same encryption key should be set for the access point and for the camera.

- (1) Type in the same character string for the key number.
- (2) Select the same key number.

Note:

- These options cannot be selected if there is no encryption key in the ENCRYPTION KEY boxes.
- The settings for ESS ID and ENCRYPTION KEY (when encryption is enabled) are verified between the STA (camera) and the HP (access point).

⑤ Ask the network administrator for the settings below, and type them in the appropriate boxes.

- IP ADDRESS
- SUBNET MASK
- GATEWAY ADDRESS

5 Once the settings have been completed, click the [SET] button, turn the power off, and then turn it back on again. This causes the settings to be accepted.

Network Camera Settings

C PPP SET Settings

These settings are used in order to connect the camera to the Internet via a modem.

Note: When using modem connections, you cannot access the camera using a computer's web browser. You should normally connect the camera to a wired LAN or wireless LAN.

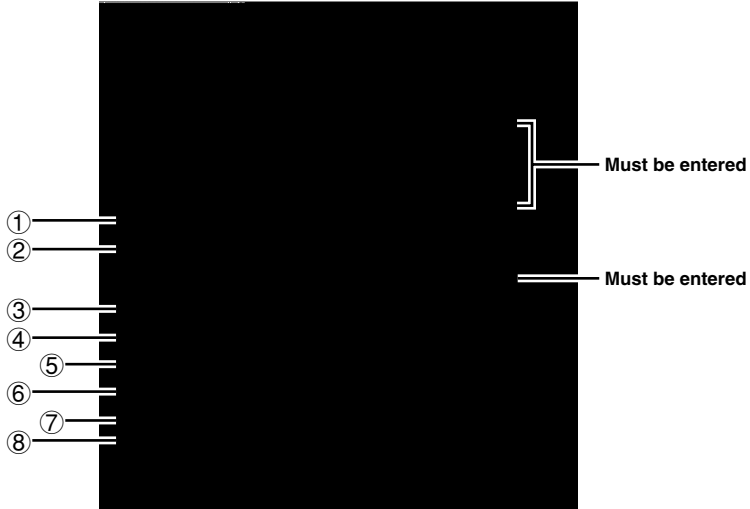

1 Install the Network Archiving software (sold separately) to the computer.

Refer to the documentation provided with the Network Archiving software for further details.

2 Set pin 1 of the PC/MODEM select switch at the rear of the camera to the "MODEM" setting.

3 Click the [PPP] button in the main menu.



The initial PPP SET window will be displayed.

4 Select "USE" from the [PPP USE] drop-down list box.

5 Type in the telephone number, login ID and password for the access point to connect to.

- PROVIDER TEL. NO.
- LOGIN ID
- PASSWORD

6 Type in the commands to use for controlling the modem.

Type in the commands starting with "AT" that are specified by the modem manufacturer in the [MODEM INITIALIZE COMMAND] box, and also type in the command to change the flow control setting to software flow control in the same box.

Change any other settings as required using the drop-down list boxes.

7 Once you have finished changing the settings, click the [SET] button.

Network Camera Settings

① AUTHENTICATION

This sets the verification protocol to be used when connecting to the access point. Set this to the protocol specified by the Internet Service Provider. It should normally be set to "AUTO".

Available settings:

- **AUTO:** PAP or CHAP is chosen automatically as required
- **PAP:** Only PAP verification is used.
- **CHAP:** Only CHAP verification is used.

② CIRCUIT TYPE

This sets the type of telephone circuit that the modem is connecting to.

Available settings:

- **TONE:** For tone dialing circuits
- **PULSE:** For pulse dialing circuits

Note: Set to "TONE" if using a terminal adapter.

③ BAUD RATE

This sets the communication speed for the modem.

Available settings: 115200, 38400 (bps)

④ DATA SIZE

Available settings: 8, 7 (bits)

⑤ PARITY

This sets the parity.

Available settings:

- **NONE:** No parity
- **EVEN:** Even parity
- **ODD:** Odd parity

⑥ STOP BIT

Available settings: 1, 1.5, 2

⑦ AUTO IP ADDRESS display

This shows the IP address for the camera.

Note: This is only displayed while the camera is connected.

⑧ ERROR INFO. display

This shows error information relating to the previous PPP connection.

Display details:

- Modem timeout or Not connected
- Line connection error
- Line disconnected
- PPP connection error
- PPP verification error
- PPP connected and disconnected normally

Menu Screen and Main Menu

- The menu screen is first displayed when the network camera and computer settings have been completed and the language selection is being made. The initial menu screen shows live images.
- The main menu can be used to select items that require settings, to select the image quality for live images, and to disconnect the camera from the network. The main menu is displayed to the left of the menu screen for all menu items except the "VIEW FRAME" item.

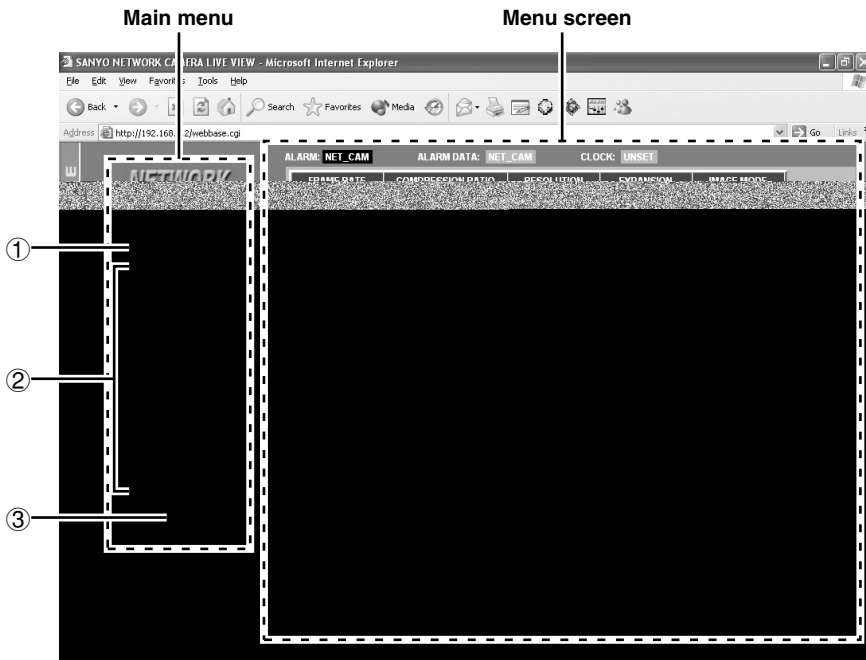

■ Main menu

① AUTO/FINE radio buttons

The images from the network camera are compressed according to the JPEG2000 format and are displayed as live images.

These two radio buttons are used to select whether the quality of the transmitted images is to be adjusted automatically in accordance with the performance specifications of the computer before being displayed, or whether the quality is to be set to fine mode regardless of the performance specifications of the computer.

- **AUTO:** The quality of the images is adjusted automatically (default setting).

Note: The quality of the images will vary depending on the capabilities of the computer. If this is a problem, change the setting to "FINE". However, when fine mode is selected, the image display speed will be slower.

- **FINE:** Images are displayed in fine mode.

Menu Screen and Main Menu

② Menu select buttons

When you click on one of these buttons, the menu screen changes to the screen corresponding to that button, and you can use the screens to change the camera settings and other setting such as for the network.

- **[LIVE VIEW] button (p. 28)**

This button lets you monitor camera images. The live image screen is the initial menu screen that is displayed. Live images are displayed automatically when this menu screen is displayed.

- **[VIEW FRAME] button (p. 31)**

When this button is clicked, the menu screen setting items disappear and the images are displayed in the image area at a fixed size (720 x 480: RESOLUTION).

- **[NETWORK] button (p. 18)**

This button is used to display and change network settings.

- **[WIRELESS LAN] button (p. 20)**

This button is used to display and change wireless LAN settings.

- **[PPP] button (p. 22)**

This button is used to display and change the settings used when the camera is connected to the Internet via a modem.

Note: This is only possible when the Network Archive software (sold separately) is used.

- **[CAMERA] button (p. 32)**

This button is used to display and change settings such as network camera image quality.

- **[ALARM] button (p. 35)**

This button is used to display and change alarm recording settings and other settings such as motion sensor settings.

- **[CLOCK] button (p. 43)**

This button is used to display and change the camera date and time setting and the summer time setting.

- **[RS-232C] button (p. 44)**

This button is used to display and change the communication speed when the camera is connected directly to a computer.

- **[STATUS] button (p. 44)**

This button is used to display the firmware version and camera status information.

③ Network disconnect button

Click this button to disconnect the camera from the network. The camera will be disconnected from the network, and “**SANYO NETWORK CAMERA, THE UNIT IS DISCONNECTED!**” will be displayed.

■ Menu screen

The menu screen changes when you click on one of the menu select buttons in the main menu.

The initial menu screen that is displayed is the live image screen. The administrator can use this screen to change the settings for transmitting live images from the camera.

You can view the images from a camera by starting up the computer's web browser and using it to access the camera's network address.

Opening and Closing the Initial Screen

1 Start the web browser on the computer.

2 Type the IP address (<http://...>) into the location bar of the web browser, and then press the [Enter] key.

The password entry window will be displayed.

Note: Type in the IP address that was set in "Network Settings". (p. 18)

3 Type your username and password in the password entry window, and then click the [OK] button.

The usernames and passwords can be set for three different access levels (User, Operator and Administrator).

The username that you enter should be either ID1, ID2 or ID3, depending on the access level. Then enter the password that corresponds to the access level selected. Refer to the [PASSWORD] item in the [NETWORK SET] settings to check the password. (p. 18)

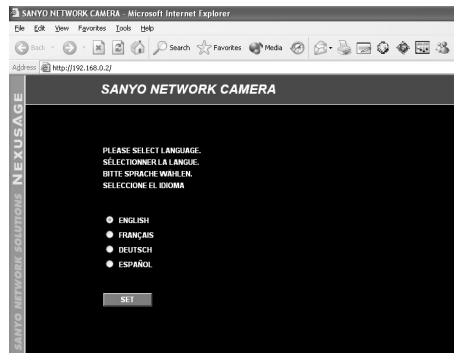
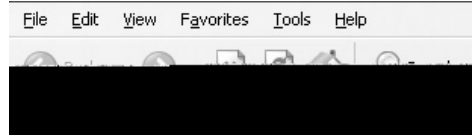

The factory default settings are as follows. Type in the password for the required user level.

- For User access level
Username: ID1; Password: 1111
- For Operator access level
Username: ID2; Password: 2222
- For Administrator access level
Username: ID3; Password: 3333

NOTE In order to make it easier to refer to this Instruction Manual when carrying out the various camera operations, the usernames **ID1**, **ID2** and/or **ID3** corresponding to the access levels for each command are indicated in the top-right corner of the page. (For example, if ID3 appears, then the operation is only available at the Administrator level.)

Viewing Camera Images

- 4** Select the language and then click the [SET] button.

The main menu screen will be displayed.

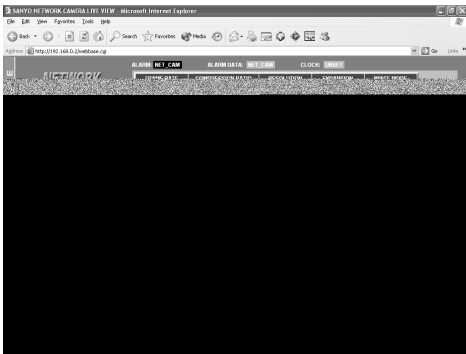

- 5** When you have finished, click the network disconnect button.

Click the [LIVE VIEW] button in the main menu.



The live image screen will be displayed. The live image screen lets you make settings such as alarm data detection and recording status, and also for the image quality, compression ratio, image size and enlargement ratio for the images that are being transmitted.

If selecting setting values for items from the drop-down list boxes, be sure to click the [SET] button after making a selection.

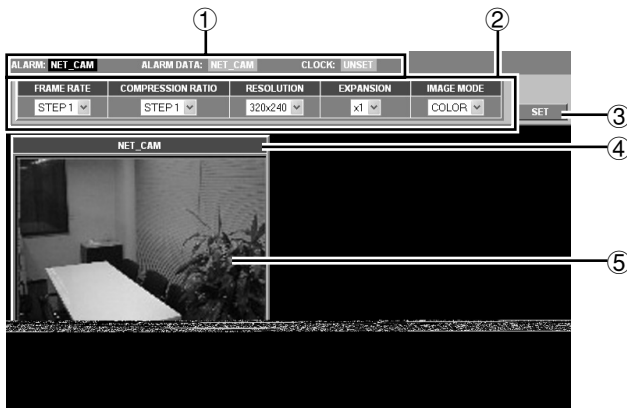

① Alarm detection and recording status

A ALARM indicator

ALARM: NET_CAM

- **Lit red (camera title)**
During alarm recording
- **Lit orange (camera title)**
Illuminates during pre-alarm recording and while images are being copied to a memory card

When recording of alarm images is finished, the indicator switches off.

B ALARM DATA indicator

ALARM DATA: NET_CAM

- **Lit red (camera title)**
This indicates that alarm images have filled the camera's internal memory (16 MB) or filled the memory card that has been inserted into the PC card slot of the camera. Alarm image playback is possible at this time.

● Lit orange (camera title)

This indicates that alarm images are being transferred from the camera's internal memory to the memory card, that alarm recording is in progress, or that a memory card error has occurred.

● Lit green (NET_CAM)

This indicates that there is some free space available in the alarm recording area when a memory card is inserted into the camera. Alarm image playback is possible at this time.

Note: Refer to “**Alarm settings**” for details on checking alarm images and alarms. (p. 35)

C CLOCK UNSET indicator

CLOCK: UNSET

This indicates the time has not yet been set. Accordingly, “**UNSET**” is displayed only when the time has not been set, and it disappears automatically once the time has been set. Click the [CLOCK] button in the main menu to set the time. (p.43)

LIVE VIEW Settings

② Live image transmission settings

Select the required setting from the respective drop-down list boxes, and then click the [SET] button.

A FRAME RATE setting

This lets you set the image transmission speed to one of five settings. Images can be transmitted at maximum speed depending on the network environment that the camera is connected to. The default setting is “STEP 5”.

Note: For example, if the maximum transmission speed for the network being connected to is 15 fps, then the images can only be transmitted at a maximum speed of 15 fps, even if the frame rate is set to “STEP 4” or higher.

(Guide to maximum speed)

Menu	Maximum
STEP1	5 fps
STEP2	10 fps
STEP3	15 fps
STEP4	20 fps
STEP5	30 fps

B COMPRESSION RATIO setting

This lets you set the compression ratio to one of five settings. If a higher compression ratio is used (STEP 1), the volume of image data becomes smaller (the amount of image deterioration becomes greater) and the transmission speed becomes faster.

The default setting is “STEP 3”.

Note: Alarm image recording is carried out at the compression ratio that is specified in the alarm recording settings, not at the setting that is made here.

C RESOLUTION setting

This lets you set the image resolution to one of five settings. The higher the resolution (720x480), the larger is the volume of data. The default setting is “640x480”. The size of the live image screen changes each time the resolution setting is changed.

Note:

- When images that are compressed using JPEG2000 are played back, the image refresh rate will vary depending on the performance specifications of the computer being used. In addition, if other applications besides the web browser are running, this may also cause the image refresh rate to become slower or may result in unstable operation. You should avoid running other applications at the same time as much as possible.
- Alarm image recording is carried out at the resolution that is specified in the alarm recording settings, not at the setting that is made here.

D EXPANSION setting

This lets you set the enlargement ratio (x2 or x4) for the live image screen. The enlargement ratio will vary depending on the RESOLUTION setting. (Table 1)

(Table 1)

RESOLUTION	EXPANSION
160 x 120	x2, x4
320 x 240	x2
640 x 480	x1 only
720 x 480	

Note: The images are enlarged to the resolution that is set by the RESOLUTION setting.

LIVE VIEW Settings

E IMAGE MODE setting



This lets you set whether live images are displayed in color or black and white. The default setting is color mode (COLOR). To change the mode to black and white, select “GRAY”.

If you select “GRAY”, the amount of data transmitted will be reduced, so that the transmission speed can be increased.

Note: If pre-alarm recording has been set, the compression ratio and resolution cannot be set.

3 [SET] button



This button is used to accept the settings in the drop-down list boxes.

4 Camera title display

Click on the [CAMERA] button in the main menu and type in the title for the camera in the “CAMERA TITLE” field. This setting will be used as the camera title in displays. (p. 32)

This same camera title is displayed as part of the “ALARM” and “ALARM DATA” indicator displays.

5 Live image screen display

The images from the camera are displayed here according to the settings for the transmission of live images. (p. 28)

Saving Images into a Computer

The camera images that are being monitored can be saved as still images in the computer's storage area in JPEG2000 format.

1 When the image to be saved is being displayed in the live image screen, right-click the camera image.

The image will be displayed as a still image and the image save pop-up menu will be displayed. Click on this pop-up menu to display the image save dialog box.



2 Type in the filename and click the [Save] button.

The image will be saved into the computer.

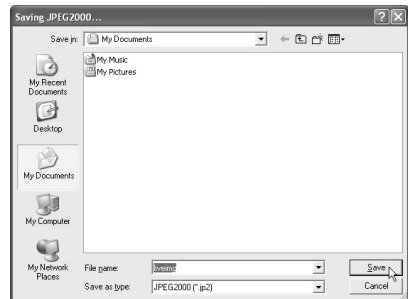

Note:

- When saving images into a computer, the images will be saved at the selected resolution.
- The extension used for the saved images will be “.jp2”.

VIEW FRAME Operations

Click the [VIEW FRAME] button in the main menu.

The menu select buttons will disappear and only the image in the live image screen will be displayed.

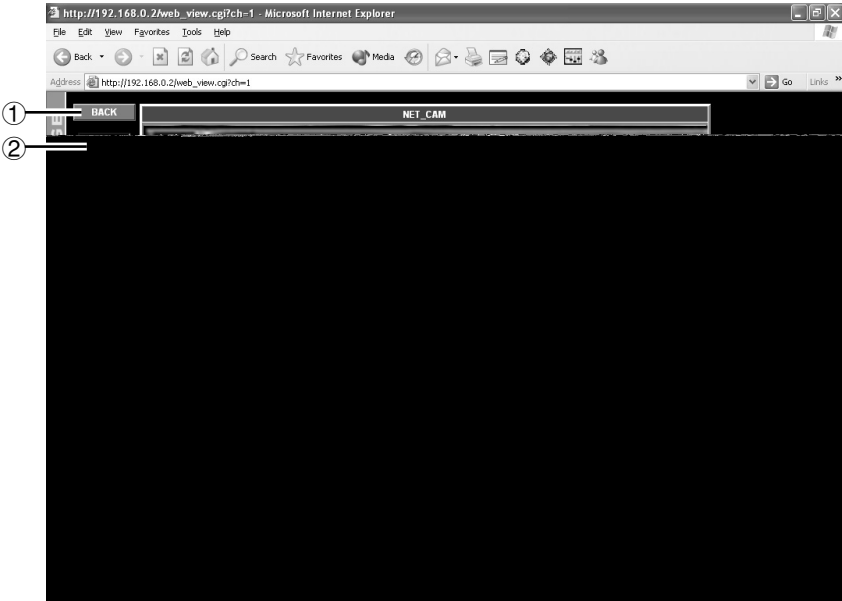

① [BACK] button

Click to return to the previous screen.

② Network disconnect button

Click to disconnect from the network.

Note: The resolution for the VIEW FRAME screen will be fixed at 720 x 480 regardless of the RESOLUTION setting. For example, if RESOLUTION is set to "320 x 240", the images will be enlarged when they are displayed.

CAMERA Settings

This lets you set the camera title and adjust the images in accordance with the camera setting-up conditions.

Click the [CAMERA] button in the main menu.

The CAMERA SET screen will be displayed.

Note:

CAMERA Settings

⑤ BRIGHT

This lets you set the image brightness to one of five settings.

Setting range: 1 to 5 (Default: 3)

Note: The larger the setting, the brighter are the images.

⑥ ELECTRONIC SHUTTER

This setting is used when IRIS is set to "AI".

Setting range: 1/60, 1/100, 1/250, 1/500, 1/1000, 1/2000, 1/4000, 1/10000

⑦ BLC (backlight compensation)

Available settings:



- **OFF:** Backlight compensation is not carried out.
- **MULTI (multiple point photometry):** Backlight compensation is calculated from the whole image to obtain correct images.
- **CENTER (center focus photometry):** Backlight compensation is calculated based on the center of the image to obtain correct images.

⑧ WHITE BALANCE

Available settings:

- **AUTO (automatic white balance):** The white balance is adjusted automatically to obtain correct colors even if the light source changes.
- **INDOOR:** This setting is for when the camera is being used indoors under fluorescent lighting.
- **OUTDOOR:** This setting is for when the camera is being used outdoors under natural sunlight.
- **MANUAL (manual white balance):** This lets you make manual fine adjustments to the white balance. It can be used when the "AUTO" setting does not give correct color reproduction.

⑨ Setting manual white balance (MANUAL)

Click the  and  buttons repeatedly to adjust the settings for **R** (red) and **B** (blue).

Setting range: 0 to 255

Note: The red or blue component becomes stronger when the setting is higher.

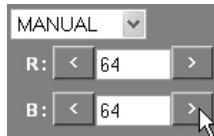

⑩ AGC Gain

If the images are too dark, change the maximum [AGC Gain] value to make the images lighter.

The default setting is "0".

Available settings:

OFF: AGC is not used.

-6 dB, 0, +6 dB, +9dB

⑪ GAMMA

Select a value that is suitable for the monitor being used.

Setting range: 1, 0.8, 0.6, 0.45, 0.3

⑫ [PRESET] button

Click this button to return all settings to their factory defaults. The preset confirmation dialog box will be displayed. Click the **[OK]** button to return the values to their factory defaults.



CAMERA Settings

■ Setting the camera title

- 1 Move the cursor to the current camera title (e.g. NET_CAM), and delete the title.

CAMERA SET	SET VALUE
CAMERA TITLE	NET_CAM

- 2 Type in the new camera title (e.g. CAM_1).

CAMERA SET	SET VALUE
CAMERA TITLE	CAM_1

The camera title can be up to eight characters in length, and may include alphanumeric characters and the underscore character only.

- 3 Click the [SET] button.

The new camera title will be saved and it will appear in the camera title display of the live image screen.

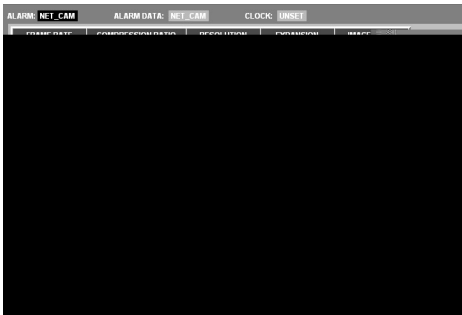

The camera is equipped with two types of alarm function: an external alarm sensor and a motion sensor. When an outside intruder is detected, these alarm functions can be used to record the images immediately before the alarm occurred (pre-alarm recording) and the alarm images themselves (post-alarm recording) into the camera's internal memory or onto a memory card.

When an alarm is received, the ALARM indicator illuminates red on the live image screen, so that you can check if an alarm is being received or not.

External Alarm Sensor Settings

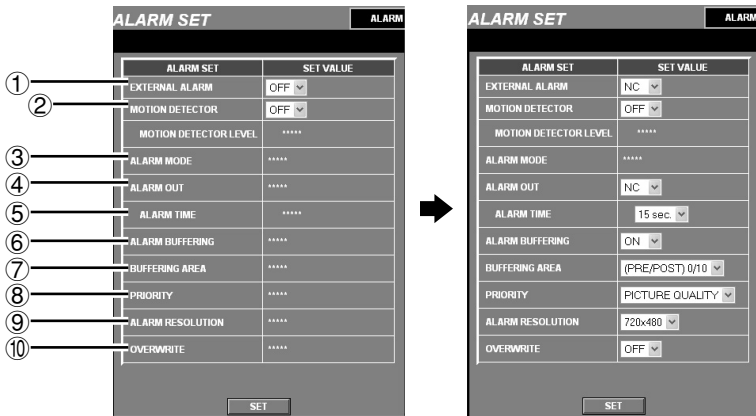

1 Make the following connections.

When using this unit, the supplied clamping core **A** must be installed on the power cord, in order to prevent electromagnetic interference to the other devices connected.

- ① Connect an infrared sensor or similar to the ALARM IN terminal at the rear of the camera.
- ② Connect a buzzer or lamp to the ALARM OUT terminal.

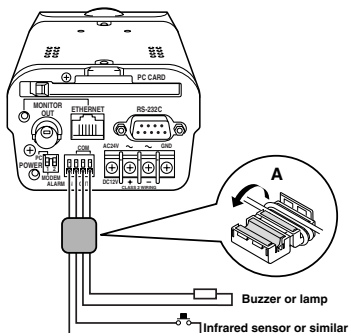

2 Click the [ALARM] button in the main menu.



The ALARM SET screen will be displayed.

3 Change the EXTERNAL ALARM setting to "NC" or "NO".

You can then select the items that are required for setting external alarms.

Note: Set MOTION DETECTOR to "OFF".

Alarm Setting

4 Set the following alarm recording settings as required.

When an alarm signal is input, the alarm data is stored in the camera's memory.

- ALARM BUFFERING "ON"
- BUFFERING AREA
- PRIORITY
- ALARM RESOLUTION
- OVERWRITE

5 Once you have finished changing the settings, click the [SET] button.

If an outside intruder activates the infrared sensor, the ALARM indicator illuminates red on the live image screen. If a buzzer or lamp is connected to the ALARM OUT terminal, the buzzer will sound or the lamp will illuminate.

① EXTERNAL ALARM setting

This sets the polarity for the infrared sensor or similar that is connected to the ALARM IN terminal at the rear of the camera.

Available settings:

- **OFF:** No external alarm input is detected.
- **NC:** Normal close (normally closed, but input is detected when open).
- **NO:** Normal open (normally open, but input is detected when closed).

② MOTION DETECTOR setting

Set to "ON" when making motion detector settings. The MOTION DETECTOR SET screen will be displayed and you can then make settings such as sensitivity level.

③ ALARM MODE setting

This sets if external alarm and/or motion sensor input triggers an alarm.

Available settings:

- **AND:** An alarm is generated when both the external alarm and the motion sensor receive alarm input.
- **OR:** An alarm is generated when either the external alarm or the motion sensor receives alarm input.

④ ALARM OUT setting

This sets the polarity for the buzzer or lamp that is connected to the ALARM OUT terminal at the rear of the camera.

Available settings:

- **OFF:** No external alarm is output.
- **NC:** Normal close (normally closed, but an alarm is output when open).
- **NO:** Normal open (normally open, but an alarm is output when closed).

⑤ ALARM TIME setting

This sets the duration of alarm output.

Available settings: 2 seconds to 5 minutes

Note: This setting is not the same as the duration of alarm recording.

⑥ ALARM BUFFERING setting

Set this to "ON" when alarm images are to be recorded.

⑦ BUFFERING AREA setting

This sets the ratio between the amount of space for the memory areas used for recording pre-alarm and post-alarm images.

Alarm Setting

⑧ PRIORITY setting

This sets the image quality for alarm recording.

● PICTURE QUALITY

Alarm images are recorded at high quality.

● TIME

Alarm images are recorded at normal quality.

* The time used for recording alarm images becomes interval shorter.

⑨ ALARM RESOLUTION setting

This sets the resolution that is to be used for recording alarm images.

The default setting is "720x240".

⑩ OVERWRITE setting

If this is set to "ON" while a memory card is inserted, old alarm data is erased and new data is recorded over the top.

■ MOTION DETECTOR SET Settings

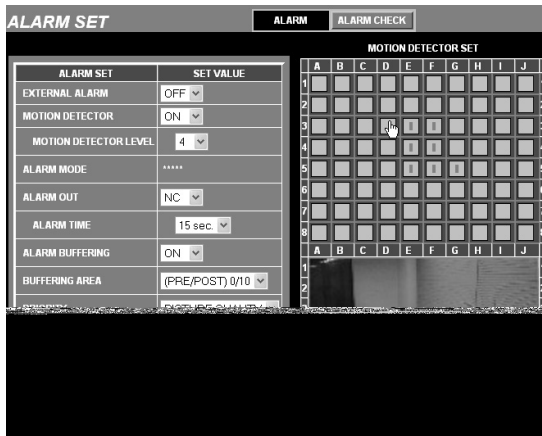

1 Click the [ALARM] button in the main menu.
The ALARM SET screen will be displayed.

2 Set MOTION DETECTOR to "ON".
The MOTION DETECTOR SET screen will be displayed.

3 While looking at the screen, move the pointer to the motion sensor detection area and click with the left mouse button.

A sensor mark (■) will appear in the detection area (grid).

Set other sensor marks in the detection area in the same way.

Note: If you click on a sensor mark that has been set, it will be cleared.

4 Click the [SET] button.

Alarm Setting

5 Check and set the sensitivity.

① Click the [ALARM CHECK] button.

The button will appear green for approximately 5 seconds. The movement of objects can only be detected during this time.

② When the sensor detects movement, the ALARM indicator will illuminate red.

This indicator will disappear momentarily when the [ALARM CHECK] button is clicked, and it will illuminate again when further movement is detected.

③ To set the sensitivity, select a number (1 to 10) from the MOTION DETECTOR LEVEL drop-down list box.

After selecting a number, repeat steps ① and ② to make sure that the sensitivity is set to the optimum level.

6 Set the following alarm recording settings as required.

When an alarm signal is input, the alarm data is stored in the camera's memory.

- ALARM BUFFERING "ON"
- BUFFERING AREA
- PRIORITY
- ALARM RESOLUTION
- OVERWRITE

7 Once you have finished changing the settings, click the [SET] button.

If an outside intruder comes into the motion sensor detection area, the ALARM indicator will illuminate red on the live image screen.

Alarm Data Recording Capacity

The capacity of the camera's internal alarm recording area is approximately 16 MB. The alarm recording area is divided into the pre-alarm recording area and the post-alarm recording area. The pre-alarm and post-alarm recording area sizes can be set to one of six settings using the BUFFERING AREA menu command.

In addition, if an expansion memory card has been inserted into the PC card slot at the rear of the camera, alarm data is automatically recorded onto the memory card from the camera's alarm memory when an alarm is received.

A Inserting the memory card

Check that the memory card is facing the correct way, and then insert it and slide the knob to lock it.

B Removing the memory card

Unlock the card and then press the knob.

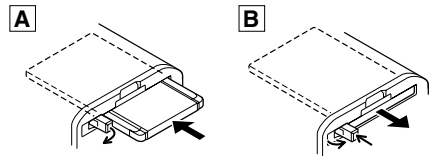

Note:

- When inserting and removing the memory card, make sure that ALARM BUFFERING is set to "OFF", and then turn off the power.
- The PC card slot is for 16-bit 5 V cards only. Do not use 32-bit card bus types of card, as the terminal sections are different.

Expansion memory cards

- The memory cards that can be used are CompactFlash memory cards with a capacity of 16 MB or greater.
- The camera does not have a formatting function. You should format CompactFlash card memory cards using your computer. The only format type that can be used is FAT.

Alarm Setting

Recording Alarm Data

The camera's internal memory can only record a single alarm event (approximately 16 MB).

When an alarm signal is input, the internal memory automatically starts recording alarm data, and this recorded data can then be played back. To record new alarm data, you need to delete the old data and clear the internal memory. If an expansion memory card has been inserted, the data recorded in the camera's internal memory is automatically transferred to the memory card. The purpose of the memory card is to store the data from the camera's internal memory, and so it cannot be used for direct recording and playback.

To play back the data that is stored on the memory card, the data needs to be transferred from the memory card back into the camera's internal memory. Refer to "**Playing Back Alarm Data**" for further details.

Note:

- Data that is stored in the camera's internal memory cannot be overwritten. To record new data, you should use the ALARM DATA LIST screen to clear the existing data in the internal memory (p. 41)
- A new alarm cannot be received while alarm data is being transferred to the expansion memory card.
- Data is not recorded directly onto the expansion memory card. The data is first recorded into the camera's internal memory, and it is then transferred automatically to the expansion memory card.
- The alarm data that has been transferred to the expansion memory card cannot be played back directly. The data that is stored on the expansion memory card is first loaded into the camera's internal memory and it is then played back. Refer to "**Playing Back Expansion Memory Card Images**". (p. 41)
- During alarm recording, the resolution and compression ratio for the images in the live image screen will be momentarily changed to the settings for alarm recording. In addition, the time taken for the images to be changed in this way may be delayed in some cases.

Playing Back Alarm Data

The data that is stored in the camera's internal memory or on an expansion memory card can be played back.

Note: If an alarm is detected while existing alarm images are being played back, the new alarm data will not be recorded. However, an alarm detection signal will be output from the ALARM OUT terminal, so that the buzzer or other device can still indicate that an alarm has been received.

1 Click the [LIVE VIEW] button in the main menu.

The live image screen will be displayed.

2 Click the ALARM DATA indicator while it is red or green.

The ALARM DATA LIST screen will be displayed.

The first image that was recorded will be displayed in the PREVIEW screen.

The alarm data will be displayed in the [ALARM DATA] list.



3 Click on an alarm filename in the [ALARM DATA] column, and then click the [PLAY] button in the PREVIEW screen.

The BUFFER DATA VIEW screen will be displayed and playback will start.

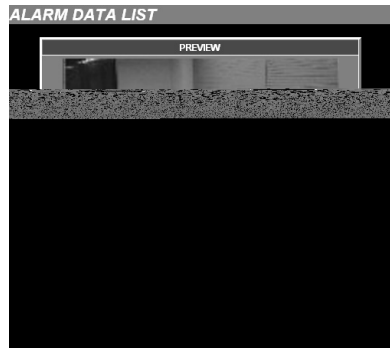

Alarm Setting

- 4 Click the [FRAME RATE] drop-down list box and select the playback speed.

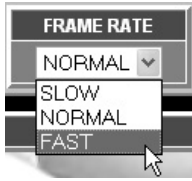

Note: The alarm data can be saved as still images on a computer. Right-click on an image that is being played back to display a pop-up menu. Refer to “Saving Images into a Computer” (p. 30) for details on the method of saving images.

- 5 Click the [ALARM] button in the main menu.

The display will return to the live image screen.

■ BUFFER DATA VIEW screen

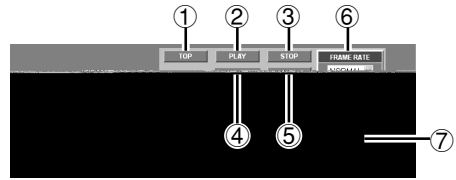

① [TOP] button

This is used to return to the start of the alarm data.

② [PLAY] button

This is used to start playback.

③ [STOP] button

This is used to stop playback.

④ [PRE/POST] display

“PRE” (playback of pre-recording images) and “POST” (playback of post-recording images) are automatically displayed during playback, and then after playback finishes, “END” is displayed. If there are no pre-recording images, playback starts from the post-recording images.

⑤ [LIST] button

This is used to return to the ALARM DATA LIST screen.

⑥ [FRAME RATE] display

The playback speed is selected from a drop-down list box. Playback starts automatically from the start of recording at the speed selected, and continues until playback is finished.

Available settings:

- **SLOW:** Slow playback speed
- **NORMAL:** Normal playback speed
- **FAST:** Fast playback speed

Note: The actual playback speed will vary depending on the alarm data volume and the network status.

⑦ Playback screen

Alarm Setting

■ Playing Back Expansion Memory Card Images

1 Click the [LIVE VIEW] button in the main menu.

The live image screen will be displayed.

2 Click the **ALARM DATA** indicator while it is red or green.

The ALARM DATA LIST screen will be displayed.

The first image that was recorded will be displayed in the PREVIEW screen.

The alarm data will be displayed in the [ALARM DATA] list.

3 Click on an alarm filename in the [ALARM DATA] column, and then click the [PLAY] button in the PREVIEW screen.

The message “**THE UNIT IS LOADING ALARM DATA**” will appear briefly, and when loading is complete, playback will start automatically.

Note:

- If you turn off the power for the camera or remove the expansion memory card while alarm data is being recorded onto or transferred from the memory card, the data may become corrupted.
- When turning off the power, make sure that the camera has finished recording data onto the memory card first.

■ Deleting Alarm Images

1 Click the **ALARM DATA** indicator w-0.0]TJ9 Tw

W..00503

Tw6W/e-14.97.36c82m 0

Alarm Setting

Pre-alarm and Post-alarm Recording

The camera can record images from the point immediately preceding an alarm (pre-alarm recording) and images that occur after the alarm is received (post-alarm recording).

The alarm data for a single pre- and post-alarm event can be recorded in the camera's internal memory. The ratio between the spaces available for pre-alarm and post-alarm recording can be set using the BUFFERING AREA command in the ALARM SET menu. The default setting is "0" for pre-alarm recording and "10" for post-alarm recording. In this case, the COMPRESSION RATIO and RESOLUTION setting values for images in the live image screen can be changed regardless of the alarm settings. (Figure 1)

However, if the BUFFERING AREA settings are changed so that the PRE/POST ratio is 1/9 or something greater than this (so that pre-alarm recording is carried out), the [PRIORITY] and [ALARM RESOLUTION] settings will be displayed in the set positions on the live image screen. In this case, the setting values are fixed, and so they cannot be change using the drop-down list box. The [IMAGE MODE] setting at this time will also be fixed at "COLOR". (Figure 2)

In addition, if [PRIORITY] is set to "PICTURE QUALITY", the compression ratio setting in the live image screen will be "STEP5", and if it is set to "TIME", then "STEP2" will be displayed.

Note: When the alarm recording capacity is filled, pre-alarm recording is canceled. Accordingly, the setting for the drop-down list box in the live image screen will no longer be fixed.

Figure 1

ALARM BUFFERING	ON
BUFFERING AREA	(PRE/POST) 0/10
PRIORITY	PICTURE QUALITY
ALARM RESOLUTION	720x480

FRAME RATE	COMPRESSION RATIO	RESOLUTION	EXPANSION	IMAGE MODE
STEP 1	STEP 1	320x240	x1	COLOR

Figure 2

ALARM BUFFERING	ON
BUFFERING AREA	(PRE/POST) 1/9
PRIORITY	PICTURE QUALITY
ALARM RESOLUTION	720x480



ALARM BUFFERING	ON
BUFFERING AREA	(PRE/POST) 1/9

FRAME RATE	COMPRESSION RATIO	RESOLUTION	EXPANSION	IMAGE MODE
STEP 1	STEP 2	720x480	x1	COLOR

This lets you set the camera's internal clock. You can also make settings for summer time.

Click the **[CLOCK]** button in the main menu.

The **CLOCK SET** screen will be displayed. Select the values from the drop-down list boxes, and then click the **[SET]** button. The settings will then be saved.



Note: If you click the **[LIVE VIEW]** button, the display will return to the live image screen.

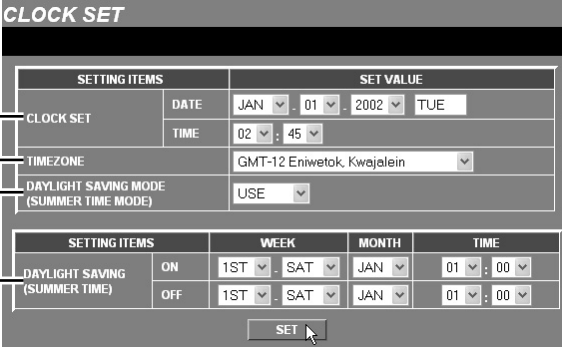

CLOCK SET

SETTING ITEMS		SET VALUE			
CLOCK SET	DATE	JAN	01	2002	TUE
	TIME	02	: 45		
TIMEZONE		GMT-12 Eniwetok Kwajalein			
DAYLIGHT SAVING MODE (SUMMER TIME MODE)		USE			

SETTING ITEMS		WEEK	MONTH	TIME	
DAYLIGHT SAVING (SUMMER TIME)	ON	1ST	- SAT	JAN	01 : 00
	OFF	1ST	- SAT	JAN	01 : 00

SET

① CLOCK SET

The default time setting is 00:00 on Jan 01 2002. Set the **DATE** and **TIME**. The weekday will be set automatically.

Note: If the time has not been set, the clock will start counting automatically from the default time setting when the power for the camera is turned on.

② TIMEZONE

This lets you set your standard time zone. Select the time zone for the camera's location.

③ DAYLIGHT SAVING MODE

This sets whether daylight saving (summer time) is to be used or not.

Available settings:

- **USE:** Daylight saving time is used.
When set to "**USE**", you can then set the times for daylight saving to be applied.
- **NO USE:** Daylight saving is not used.

④ DAYLIGHT SAVING

When the set date and time is reached, the camera's time automatically changes from standard time to summer time. You need to set the start time (**ON**) and end time (**OFF**) for summer time.

WEEK ... Sets the week and weekday.

Available settings:

- **Week:** 1ST, 2ND, 3RD, 4TH, LST
- **Day:** SUN, MON, TUE, WED, THU, FRI, SAT

MONTH ... Sets the start month and end month for summer time.

TIME ... Sets the hours and minutes.

RS-232C Settings (RS-232C SET)

ID3

This sets the communication speed for the RS-232C connector of the camera when the camera is connected to a computer for maintenance and servicing.

Click the **[RS-232C]** button in the main menu.

The RS-232C SET screen will be displayed. Select the communication speed from the drop-down list box, and then click the **[SET]** button. The setting will then be saved.

- The default setting for the communication speed is 19200 bps.

Note: If you click the **[LIVE VIEW]** button, the display will return to the live image screen.

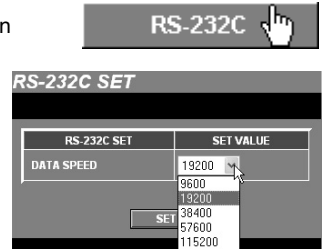

STATUS Checking

ID3

This displays information about the camera status.

Click the **[STATUS]** button in the main menu.

The ALARM DATA LIST screen will be displayed.

Note: If you click the **[LIVE VIEW]** button, the display will return to the live image screen.

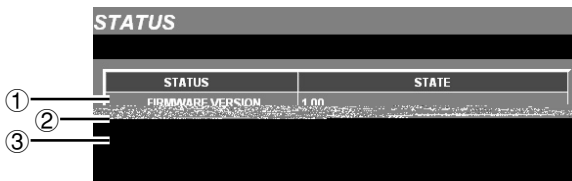

① FIRMWARE VERSION

This shows the version number for the camera's firmware.

② SUB-MICROCOMPUTER VERSION

This shows the version number for the camera's sub-microcomputer.

③ PCMCIA: SOCKET STATUS

This shows the usage status for the PC card slot.

Troubleshooting

■ If the camera cannot be connected

If the language selection window does not appear when you type the camera's IP address into the location bar of the web browser, check the following items.

● Is the Ethernet cable connected correctly?

If the cable is not connected correctly, the link indicator at the rear of the camera will not be illuminated. Check the cable connection.

Note: Cross-type and straight-type Ethernet cables are available. To connect the camera directly to a computer, you need to use a cross-type cable.

● Is the link indicator flashing?

If the link indicator is illuminated steadily, it means that the cable is connected to the camera but communication is not possible.

The default network settings for the camera are as follows.

- IP address: 192.168.0.2
- Subnet mask: 255.255.255.0
- Gateway: 192.168.0.1
- Port number: 80

■ If you forget the IP Address

If you forget the camera's IP address, you can check it using the following procedure.

- 1** Set pin 1 of the PC/MODEM select switch at the rear of the camera to the "MODEM" setting, turn off the camera's power, wait three seconds or more and then turn the power back on.
- 2** Set pin 1 of the PC/MODEM select switch at the rear of the camera to the "PC" setting, turn off the camera's power, wait three seconds or more and then turn the power back on.
- 3** Set the computer's IP address to "192.168.0.*". (Enter a number that is 3 or greater in place of "*".)

- 4** Start the web browser and point it to "http://192.168.0.2".

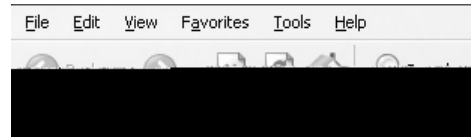

- 5** Check the network settings. (p. 18)

NETWORK SET

NETWORK SET	SET VALUE			
IP ADDRESS	192	168	0	2
SUBNET MASK	255	255	255	0
GATEWAY	192	168	0	1
PASSWORD (4-8)	ID1	1111		
	ID2	2222		
	ID3	3333		
NETWORK SPEED	NO LIMIT			
HTTP PORT NUMBER	80			
MAC ADDRESS	08-00-7B-81-18-05			

SET

- 6** Turn off the camera's power.
- 7** Return the computer's IP address to its original setting.

Note:

- If the password for the Administrator level ID has been changed, be careful not to forget the password.
- Check that none of the other devices that are connected to the network have a duplicate IP address of "192.168.0.2".

Specifications

Lens	: CS mount
Picture element	: 1/3 inch 420,000 pixel CCD
Effective pixels	: 768 (H) x 494 (V)
Minimum object illumination	: 1.0 lx (F1.2 lens)
White balance	: AUTO/INDOOR/OUTDOOR/MANUAL manually selectable
Electronic shutter	: 1/60 to 1/10000 sec.
Automatic iris	: DC drive, 4-pin
Alarm input/output	
● Input	: 1 (NO/NC)
● Output	: 1 (AND/OR output function for motion sensor and external input)
Resolution	: 720 x 480, 720 x 240, 640 x 480, 320 x 240, 160 x 120 pixel
Compression method	: JPEG2000
Compression ratio	: 5 settings (from 5 KB)
Image transfer speed	: Max. 30 fps (640 x 480 pixels)
Monitor output	: Composite video output (NTSC)
Other functions	: Color/Black & white selectable, built-in clock function
Interfaces	
● Ethernet connector	: 10/100 Base-T (RJ-45)
● RS-232C connector	: D-Sub 9-pin
● PC card slot	: PCMCIA Type II (5 V power supply only)
Pre-/post-alarm buffer	: 16 MB
Protocols	: TCP/IP, PPP, FTP, HTTP
Software	: Plug-in browser (Internet Explorer compatible)
Operating conditions	
● Temperature	: -10 ~ +50C
● Humidity	: 90% R.H. or less
Power supply	: AC 24 V/DC 12 V
Power consumption	: 10 W
Weight	: Approx. 470 g

Specifications

■ Dimensions

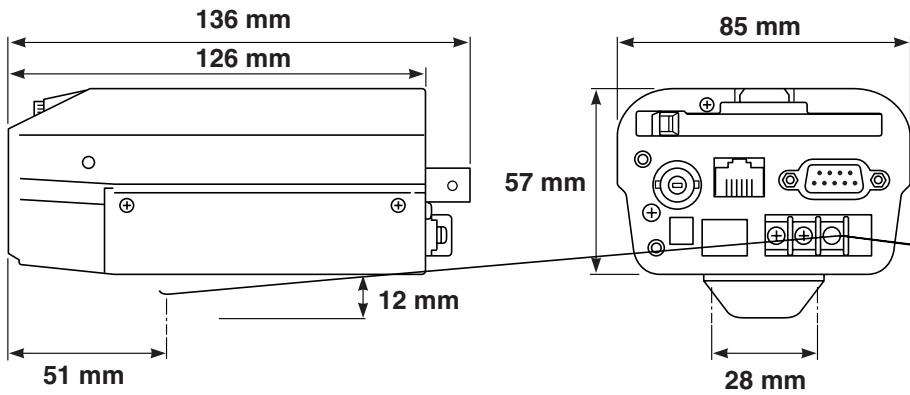

Appearance and specifications are subject to change for improvement without notice.

**SANYO INDUSTRIAL VIDEO
COLOR VIDEO CAMERA LIMITED WARRANTY**

OBLIGATIONS

In order to obtain warranty service, the product must be delivered to and picked up from an Authorized Sanyo Service Center at the user's expense, unless specifically stated otherwise in this warranty. The names and addresses of Authorized Sanyo Service Centers may be obtained by calling the toll-free number listed below.

For product operation, authorized service center referral, service assistance or problem resolution, call

**CUSTOMER INFORMATION 1-800-421-5013
Weekdays 8:30 AM -5:00 PM Pacific Time**

For accessories and/or parts, call

**PARTS ORDER INFORMATION 1-800-726-9662
Weekdays 8:30 AM -5:00 PM Pacific Time**

THIS WARRANTY IS VALID ONLY ON SANYO PRODUCTS PURCHASED OR RENTED IN THE UNITED STATES OF AMERICA, EXCLUDING ALL U.S. TERRITORIES AND PROTECTORATES. THIS WARRANTY APPLIES ONLY TO THE ORIGINAL RETAIL PURCHASER OR END-USER. THE ORIGINAL DATED BILL OF SALE, SALES SLIP OR RENTAL AGREEMENT MUST BE SUBMITTED TO THE AUTHORIZED SANYO SERVICE CENTER AT THE TIME WARRANTY SERVICE IS REQUESTED.

Subject to the OBLIGATIONS above and EXCLUSIONS below, SANYO Fisher Company warrants this SANYO product against defects in materials and workmanship for the periods specified below. SFC will repair or replace (at its option) the product and any of its parts which fail to conform to this warranty. The warranty period commences on the date the product was first purchased or rented at retail.

LABOR	PARTS	IMAGE DEVICE
3 YEARS	3 YEARS	3 YEARS

EXCLUSIONS

This warranty does not cover (A) the adjustment of customer-operated controls as explained in the appropriate model's instruction manual, or (B) the repair of any product whose serial number has been altered, defaced or removed.

This warranty shall not apply to the cabinet or cosmetic parts, batteries or routine maintenance.

This warranty does not apply to uncrating, setup, installation, removal of the product for repair or reinstallation of the product after repair.

This warranty does not apply to repairs or replacements necessitated by any cause beyond the control of SFC including, but not limited to, any malfunction, defect or failure caused by or resulting from the use of any products operated outside of the operating temperature ranges stated in our product specification, (i.e., between 41 and 104 degrees Fahrenheit or between 5 and 40 degrees Celsius), unauthorized service or parts, improper maintenance, operation contrary to furnished instructions, shipping or transit accidents, modification or repair by the user, abuse, misuse, neglect, accident, incorrect power line voltage, fire, flood or other Acts of God, or normal wear and tear.

SFC does not guarantee that recorded pictures or information will be maintained on any product sent in for repair or replacement.

The foregoing is in lieu of all other expressed warranties and SFC does not assume or authorize any party to assume for it any other obligation or liability.

SFC DISCLAIMS ALL OTHER WARRANTIES EXPRESS OR IMPLIED, WITH REGARD TO THIS PRODUCT (INCLUDING THE WARRANTIES OF MERCHANTABILITY AND FITNESS), IN NO EVENT SHALL SFC BE LIABLE FOR ANY SPECIAL, INCIDENTAL OR CONSEQUENTIAL DAMAGES ARISING FROM THE OWNERSHIP OR USE OF THIS PRODUCT OR FOR ANY DELAY IN THE PERFORMANCE OF ITS OBLIGATIONS UNDER THIS WARRANTY DUE TO CAUSES BEYOND ITS CONTROL. SFC'S LIABILITY FOR ANY AND ALL LOSSES AND DAMAGES RESULTING FROM ANY CAUSE WHATSOEVER, ARISING OUT OF OR IN CONNECTION WITH THE SALE, USE OR OWNERSHIP OF THIS PRODUCT INCLUDING WARRANTOR'S NEGLIGENCE, ALLEGED DAMAGED OR DEFECTIVE GOODS, WHETHER SUCH DEFECTS ARE DISCOVERABLE OR LATENT, SHALL IN NO EVENT EXCEED THE PURCHASE PRICE OF THE PRODUCT.

ATTENTION

For your protection in the event of theft or loss of this product, please fill in the information below for your own personal records.

Model No. _____

Serial No.
(Located on back or bottom side of unit.) _____

Date of Purchase _____

Purchase Price _____

Where Purchased _____

Printed on recycled paper

1AC6P1P2545--
L5AB2/US (0702KP-CZ)

SANYO

Printed in Japan